

120R-101658 REV.: 8

REV.	DESCRIPTION	DATE	BY

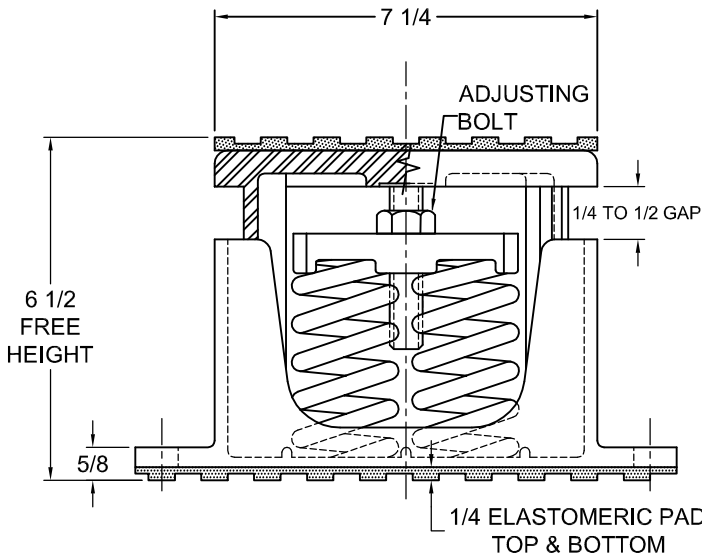
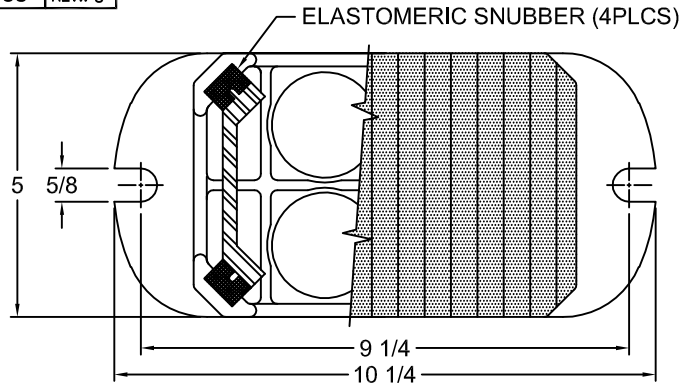

NOTES:

1. ALL DIMENSIONS ARE IN INCHES, INTERPRET PER ANSI Y14.
2. FINISH: HOUSINGS CAST IRON- ONE COAT BLACK PAINT, SPRINGS-POWER COAT,
3. HARDWARE: ZINC-ELECTROPLATE.
4. REFER TO SHEET 2 OF 2 FOR INSTALLATION INSTRUCTIONS.
5. INNER SPRING (WHEN USED) NOT SHOWN.
6. ALL SPRINGS ARE DESIGNED WITH 50% OVER TRAVEL.
7. RATED DEFLECTIONS ARE WITHIN 25% OF NOMINAL. HIGHER DEFLECTIONS ARE ALLOWED IF THEY MEET SPECIFICATIONS .

TYPE C4T-1D CAST IRON SPRING-FLEX ISOLATORS WITH EXTERNAL ADJUSTMENT

MODEL	MAX LOAD (LBS)	DEFLECTION (IN)	SPRING RATE (LB/IN)	SPRING COLOR CODE
C4T-1D-1360	1360	1.13	1200	RED
C4T-1D-2040	2040	1.02	2000	BLACK
C4T-1D-2700	2700	1.32	2052	DK PURPLE
C4T-1D-3600	3600	1.02	3524	DK GREEN
C4T-1D-4800	4800	0.90	5308	GRAY
C4T-1D-5440	5440	0.77	7032	WHITE
C4T-1D-7140N ¹	7140	0.88	8116	GRAY/ RED

NOTES:

1. TWO NESTED SPRINGS YIELD THIS LOAD. THE COLOR CODE IS FOR OUTER SPRING/ INNER SPRING



ISOLATOR SELECTIONS

LOC 1:	LOC 2:
LOC 3:	LOC 4:
LOC 5:	LOC 6:
LOC 7:	LOC 8:
CUSTOMER EQPT. TAG:	

NOTE: MATERIAL SHOWN IS FOR (1) SET.

OTHER MATERIALS, COMPOUNDS, OR FINISHES WITH EQUAL OR SUPERIOR PROPERTIES MAY BE SUBSTITUTED AS THEY BECOME AVAILABLE.

CERTIFIED FOR:

JOB NAME: _____
 CUSTOMER: _____
 CUSTOMER P.O.: _____
 SALES ORDER: _____

**MODEL C4T-1D 1360-7140 LBS.
 HOUSED CAST IRON
 SPRING- FLEX ISOLATORS SNUBBED WITH
 INTERNAL ADJUSTMENT
 1 INCH DEFLECTION**



THE VMC GROUP
The Power of Together
 Bloomingdale, NJ 07403
 Houston, TX 77041

SCALE:

NONE

SHEET:



DRAWING NO.:

REVISION

120R-101658 REV.: 8

REV.	DESCRIPTION	DATE	BY

INSTALLATION INSTRUCTION

- ISOLATORS ARE SHIPPED FULLY ASSEMBLED AND ARE TO BE SPACED AND ARRANGED IN ACCORDANCE WITH INSTALLATION DRAWINGS OR AS OTHERWISE RECOMMENDED.
- SET ISOLATORS ON FLOOR OR SUB-BASE, ENSURING THAT ALL ISOLATOR CENTERLINES MATCH THE EQUIPMENT ISOLATING HOLES. SHIM OR GROUT AS REQUIRED LEVELING ALL ISOLATOR BASE PLATES "E" AT THE SAME ELEVATION (1/4" MAXIMUM DIFFERENCE IN ELEVATION CAN BE TOLERATED). ISOLATOR BASE PLATES MUST REST ON A FLAT SURFACE.
- ONCE ISOLATORS ARE IN POSITON, PLACE BLOCKING ALONGSIDE FREE ISOLATOR. BLOCKING HEIGHT SHOULD BE EQUIVALENT TO THE HEIGHT OF THE ISOLATOR AND BE CAPABLE OF SUPPORTING EQUIPMENT WEIGHT.
- UNLESS SPECIFIED, ISOLATORS NEED NOT TO BE FASTENED TO THE FLOOR IN ANY WAY. IF REQUIRED, BOLT ISOLATORS TO FLOOR THROUGH SLOTS "D". RECOMMENDED MAXIMUM TORQUING OF THE ISOLATOR BASE ANCHORS TO 5FT-# AFTER EQUIPMENT IS INSTALLED.
- ALIGN EQUIPMENT ISOLATING HOLE TO TOP HOUSING TAPPED HOLE.
- PLACE MACHINE OR EQUIPMENT ONTO TOP PLATE "A" OF ISOLATOR. THE WEIGHT OF THE MACHINE MAY CAUSE THE UPPER HOUSING TO GO DOWN.
- TURN NUTS "B" UP ON LEVELING BOLTS SO THAT THEY WILL NOT INTERFERE WITH THE PROCEDURE. INSERT BOLTS "C" THROUGH THE HOLES IN MACHINE BASE AND SCREW INTO THE TAPPED HOLE IN THE UPPER HOUSING OF THE ISOLATOR BY HAND AS FAR AS THEY WILL GO.
- ADJUST EACH ISOLATOR IN SEQUENCE; SCREW DOWN ONE COMPLETE TURN ON THE ADJUSTING BOLT "B" OF EACH ISOLATOR UNTIL EQUIPMENT IS RAISED ABOVE BLOCKING.
- AFTER THE MACHINE OR EQUIPMENT IS LEVEL AND LOADS ARE TRANSFERRED TO SPRINGS, REMOVE BLOCKING.
- ADJUSTING BOLT "B" PLACE WITH WRENCH TO COMPLETE ADJUSTMENTS.
- INSTALLATION IS COMPLETE.

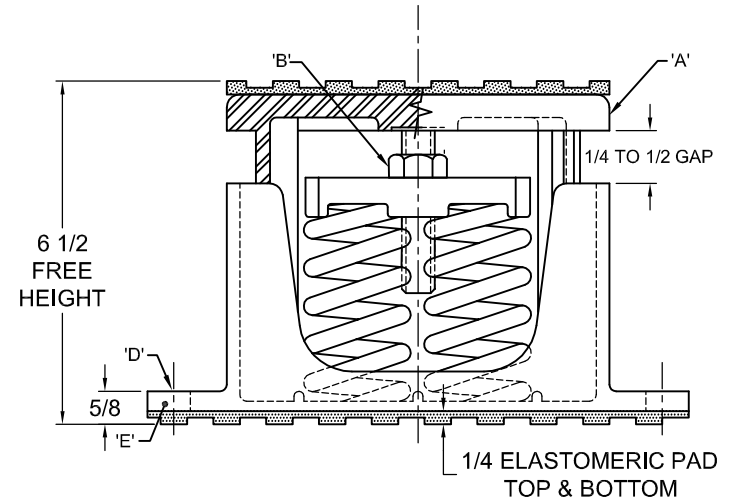

OTHER MATERIALS, COMPOUNDS, OR FINISHES WITH EQUAL OR SUPERIOR PROPERTIES MAY BE SUBSTITUTED AS THEY BECOME AVAILABLE.

CERTIFIED FOR:

JOB NAME: _____
 CUSTOMER: _____
 CUSTOMER P.O.: _____
 SALES ORDER: _____

**MODEL C4T-1D 1360-7140 LBS.
 HOUSED CAST IRON
 SPRING- FLEX ISOLATORS SNUBBED WITH
 INTERNAL ADJUSTMENT
 1 INCH DEFLECTION**



THE VMC GROUP
The Power of Together
 Bloomingdale, NJ 07403
 Houston, TX 77041

SCALE:

NONE

SHEET:



DRAWING NO.:

REVISION